

# 891

MAX: 765 x 765 x 1495 mm.  
INT: 530 x 530 x 1000 mm.

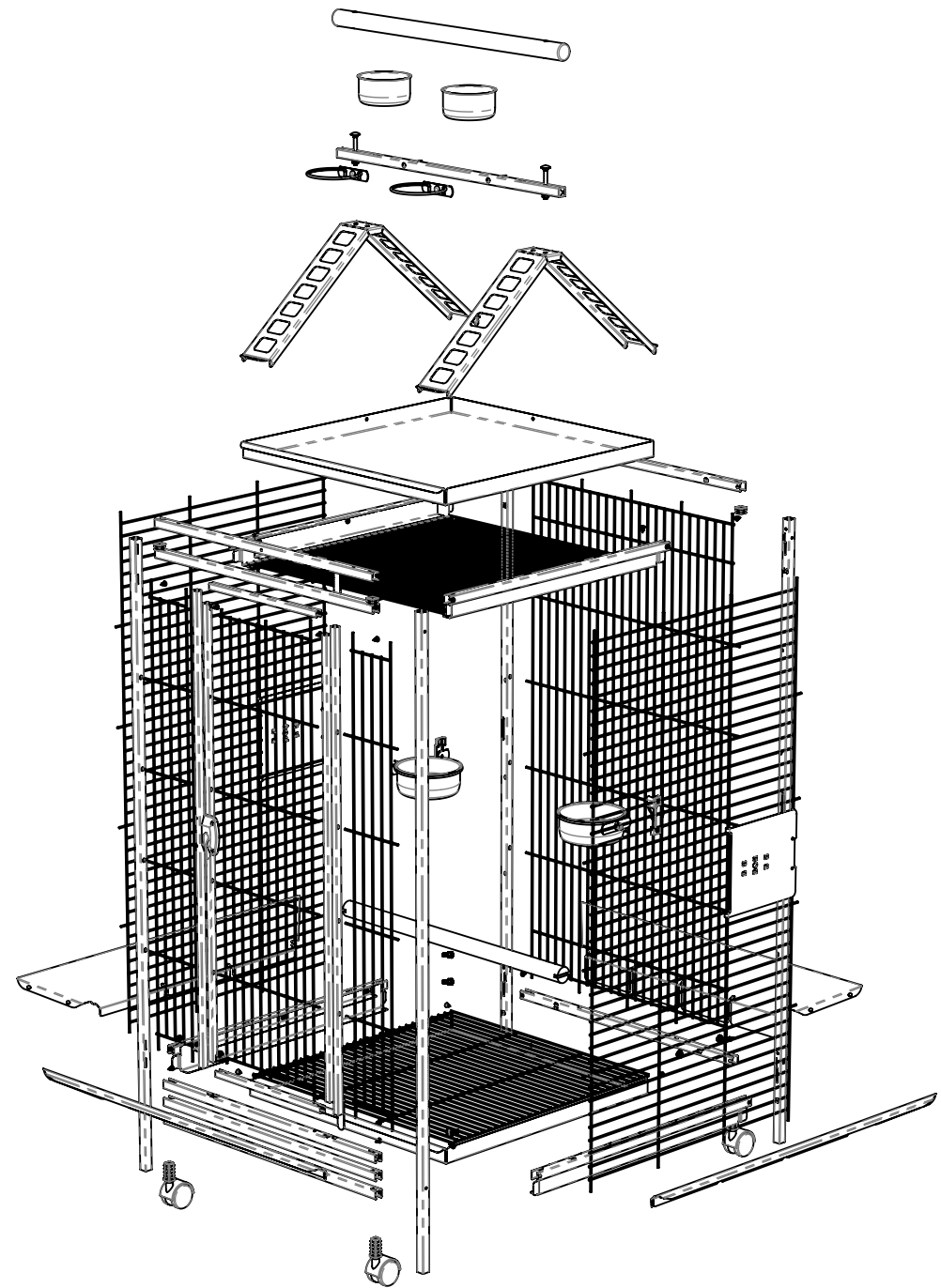

**P000891**  
V221019

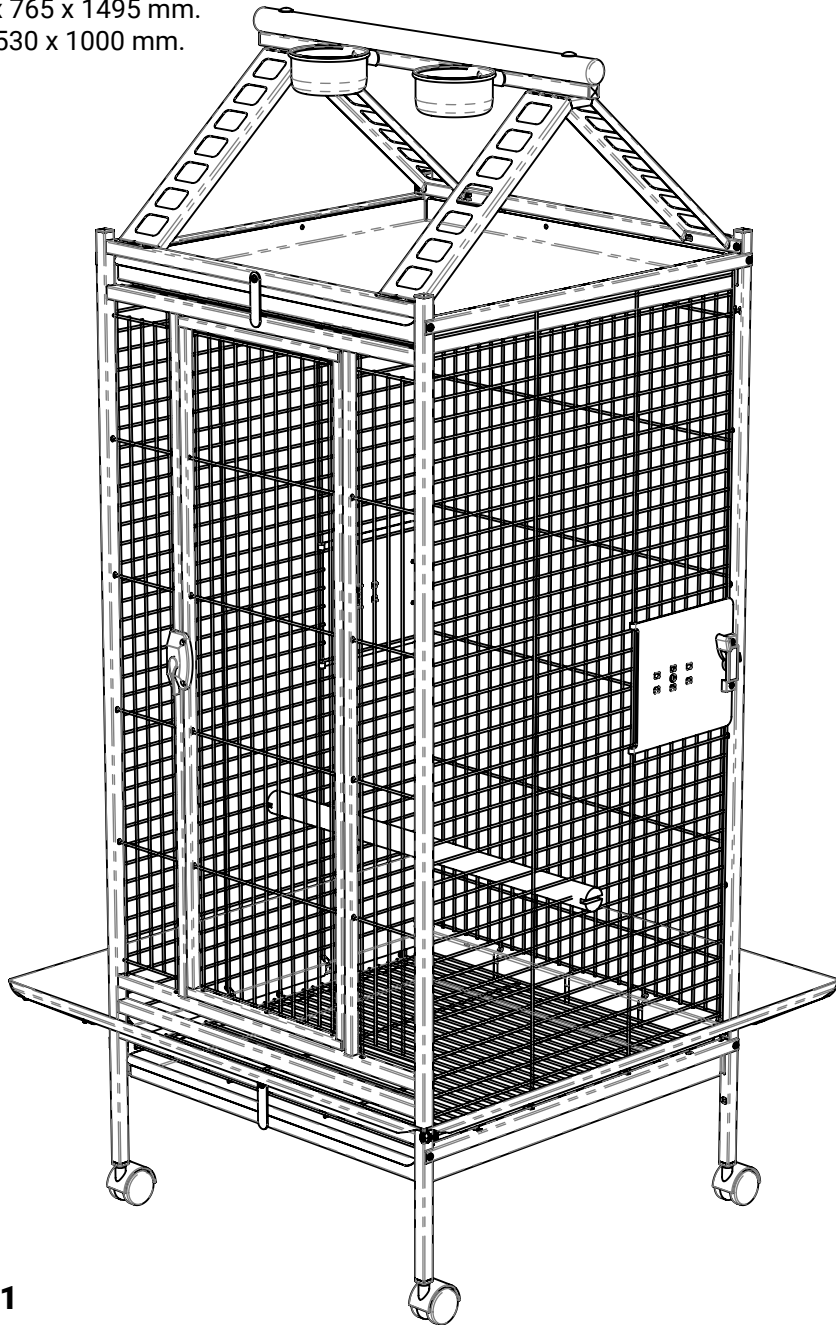
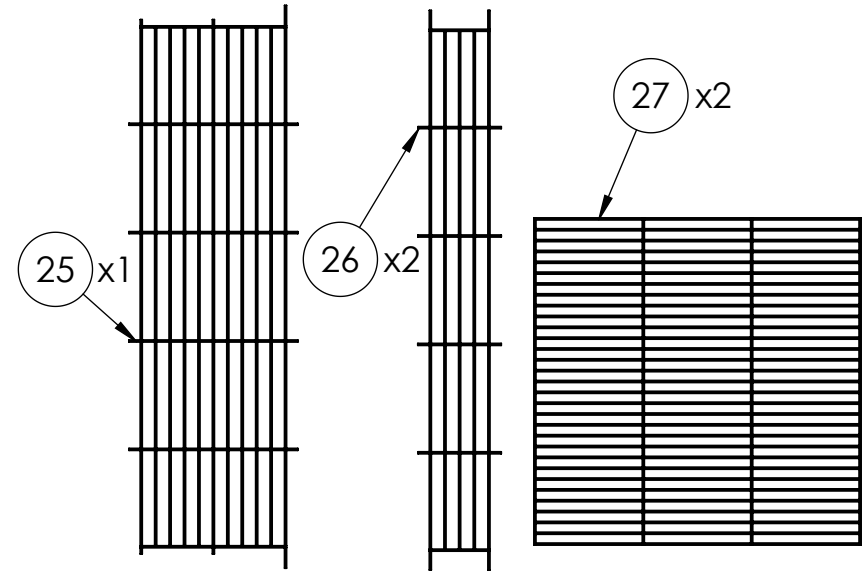
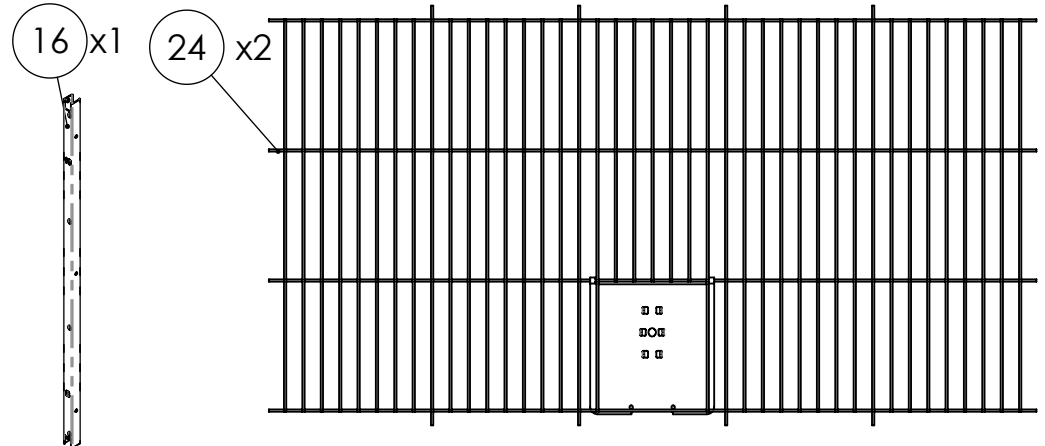
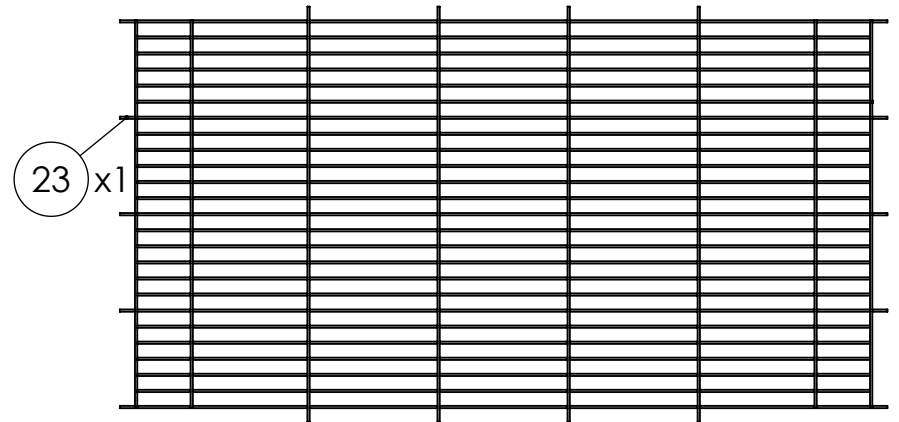
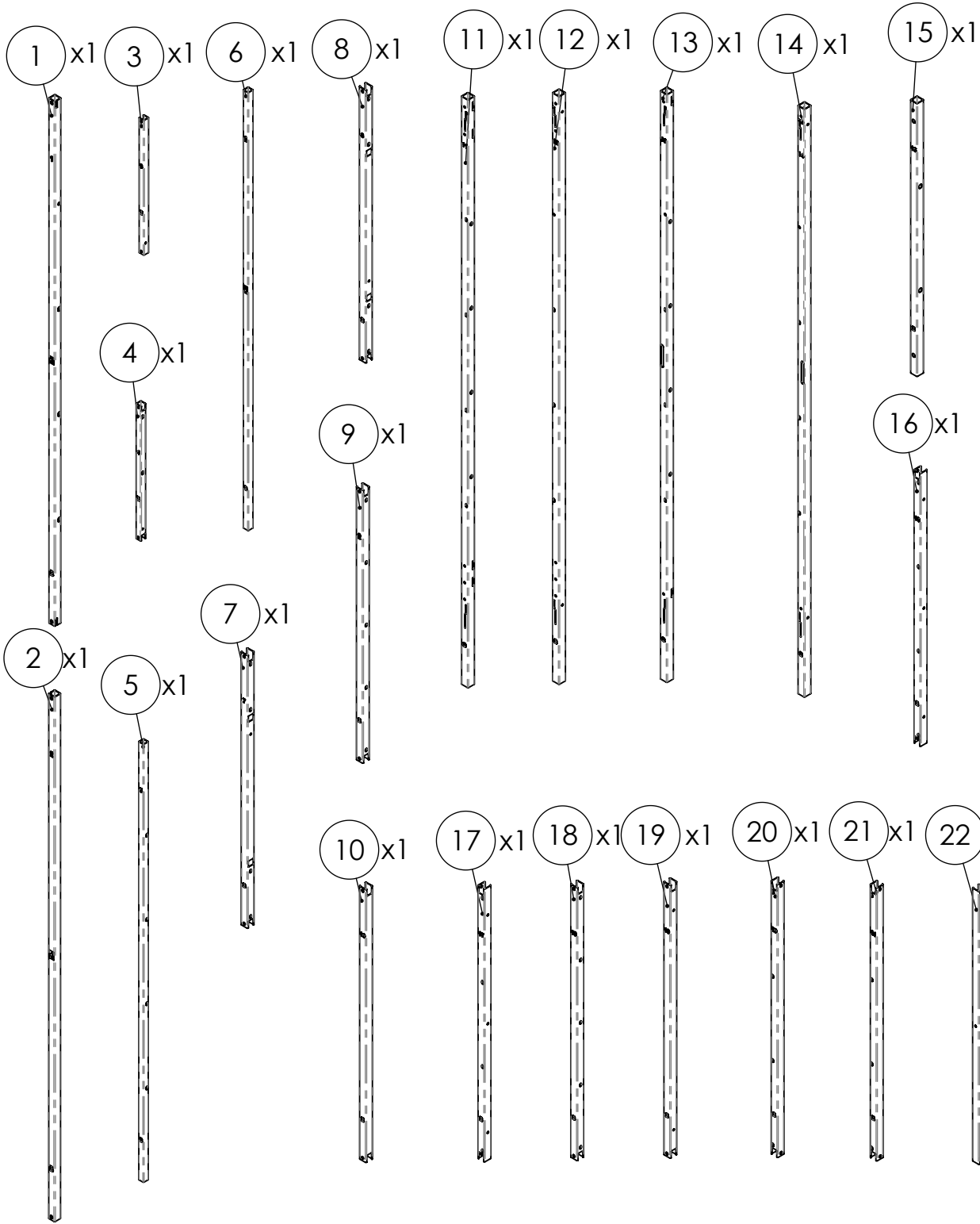

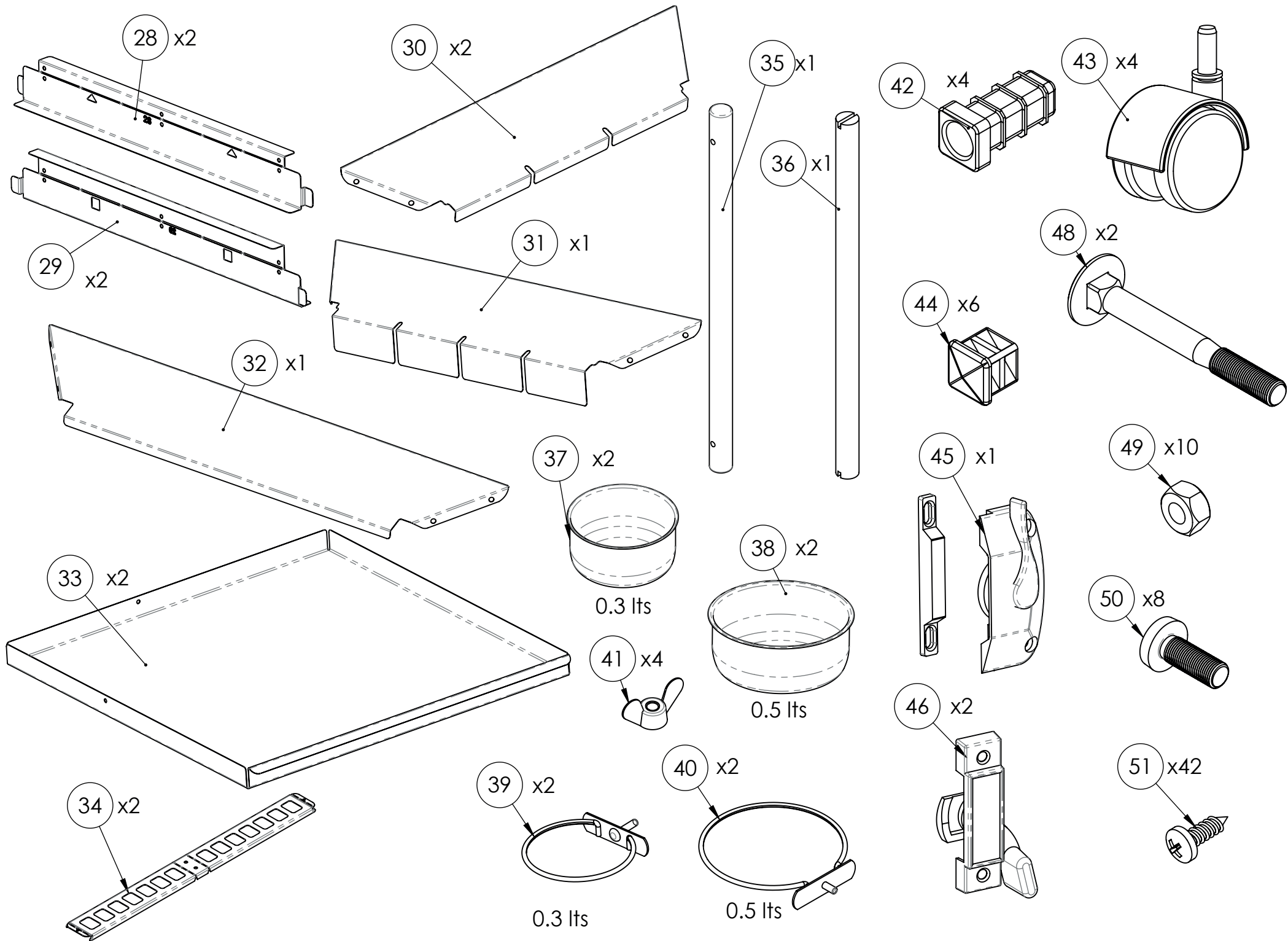

OP1

HOW TO WORK

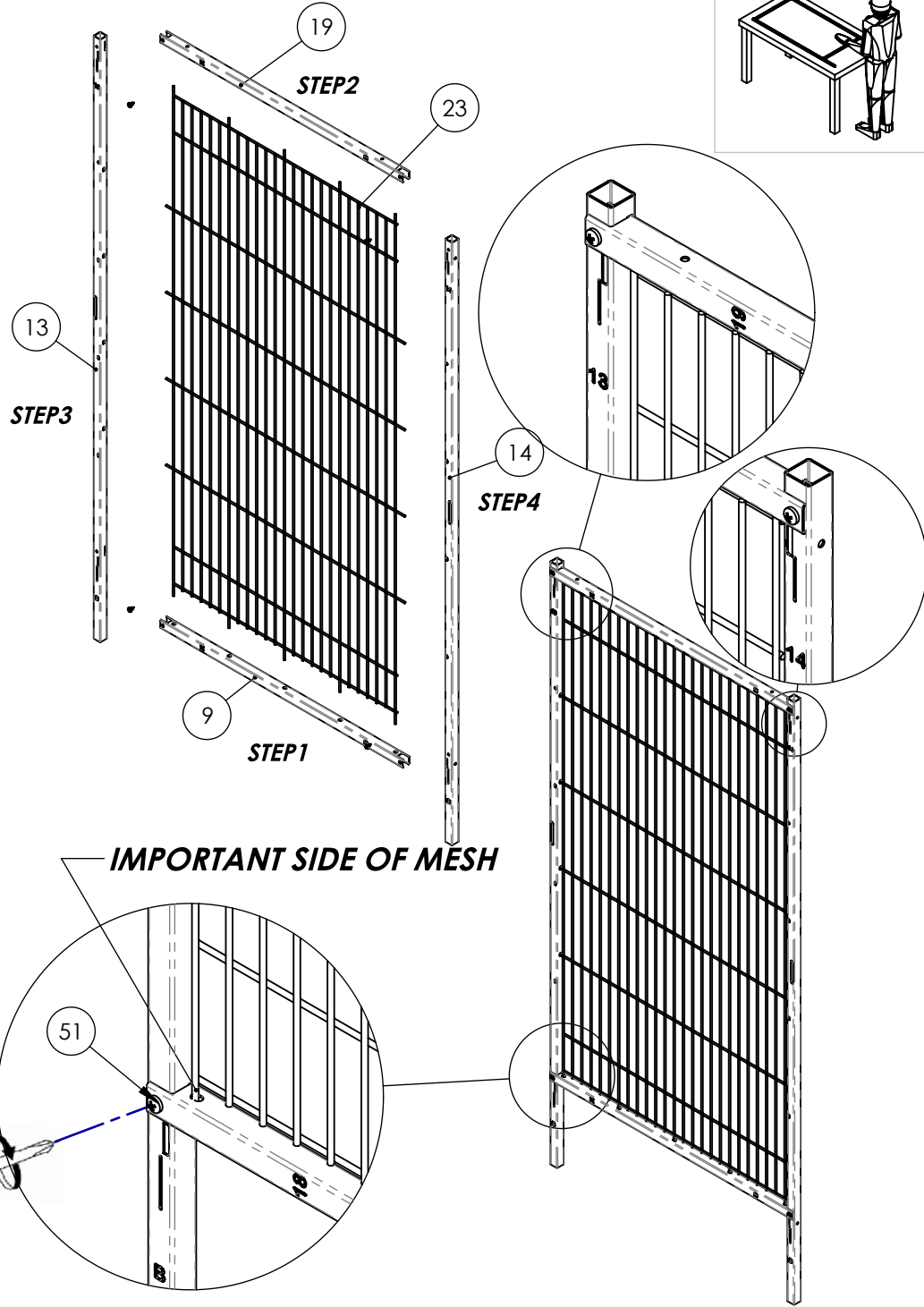
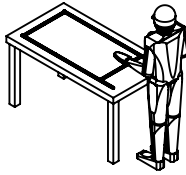

OP 2

HOW TO WORK

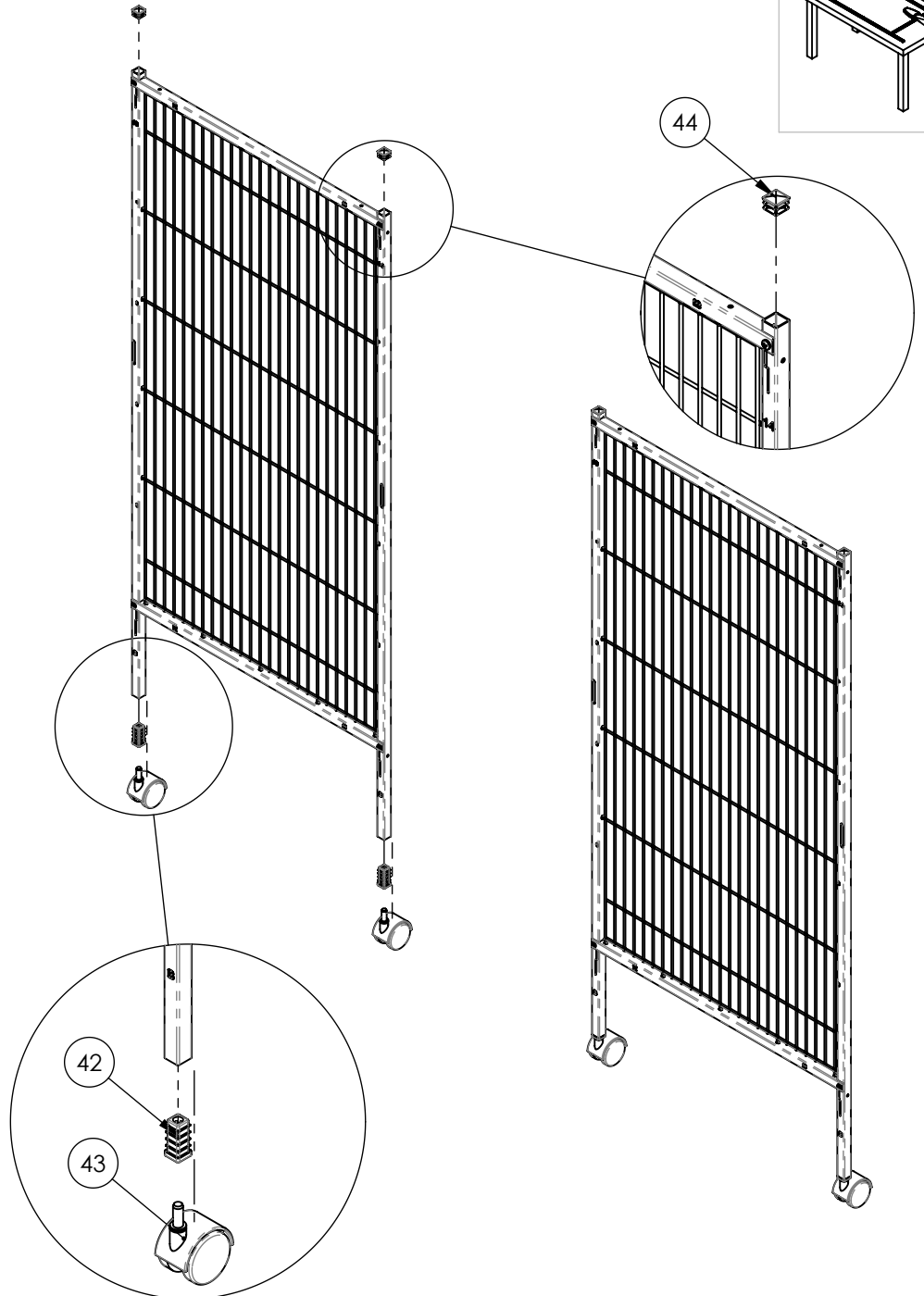
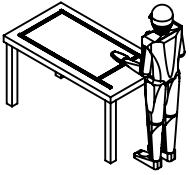

OP3

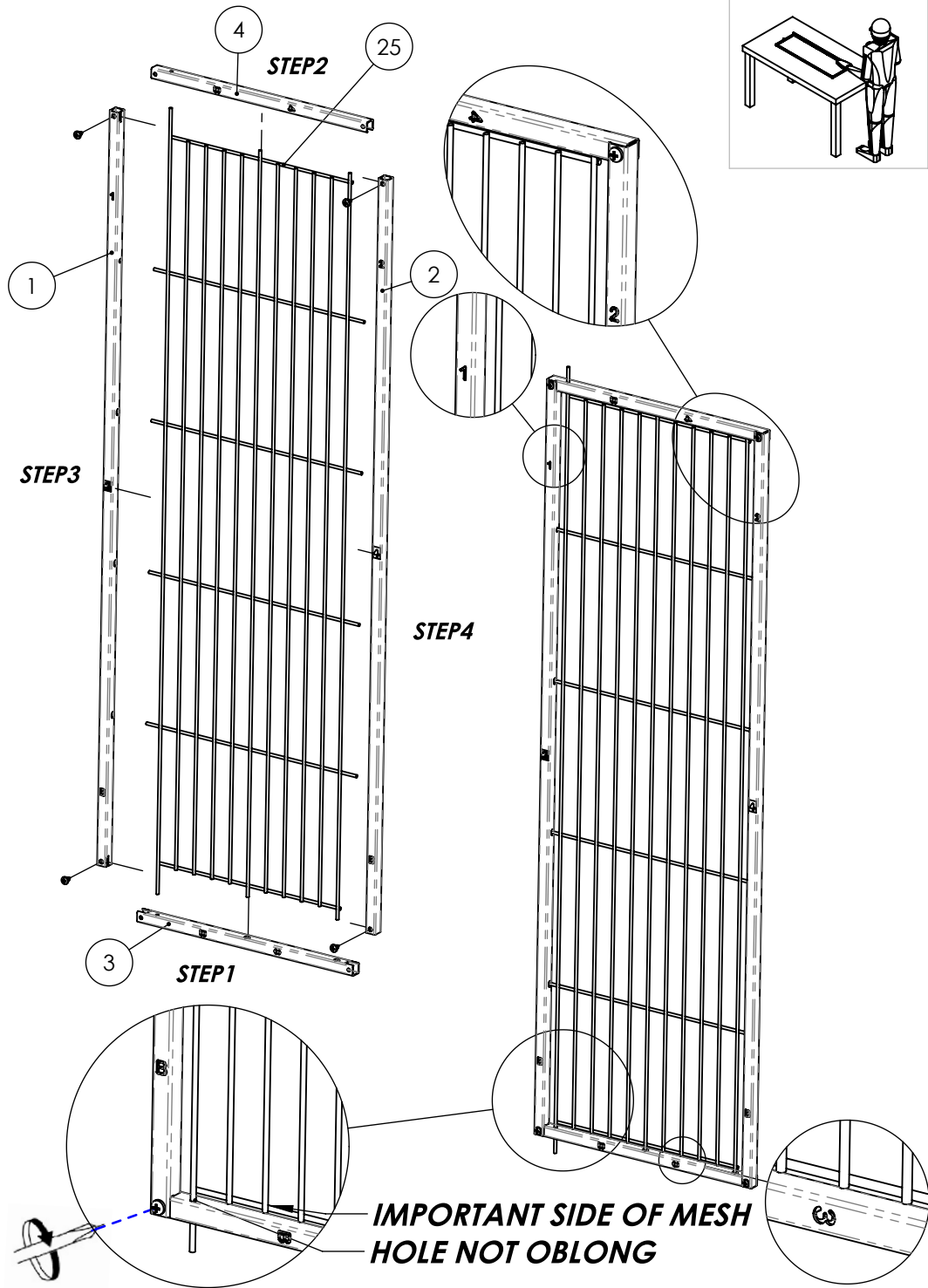

HOW TO WORK

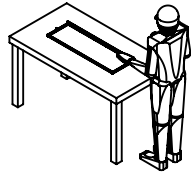

OP4

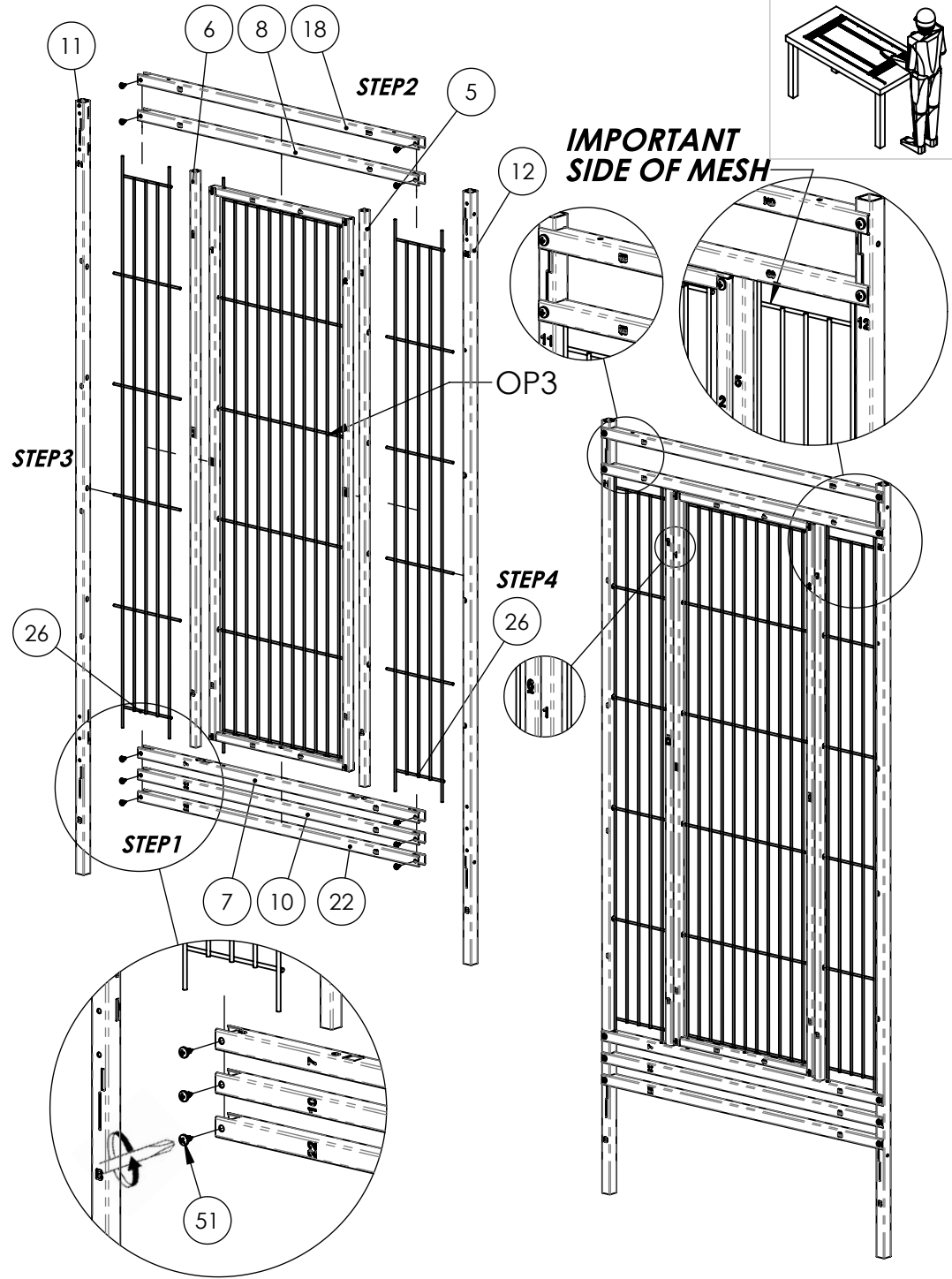

HOW TO WORK

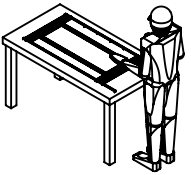

OP5

HOW TO WORK

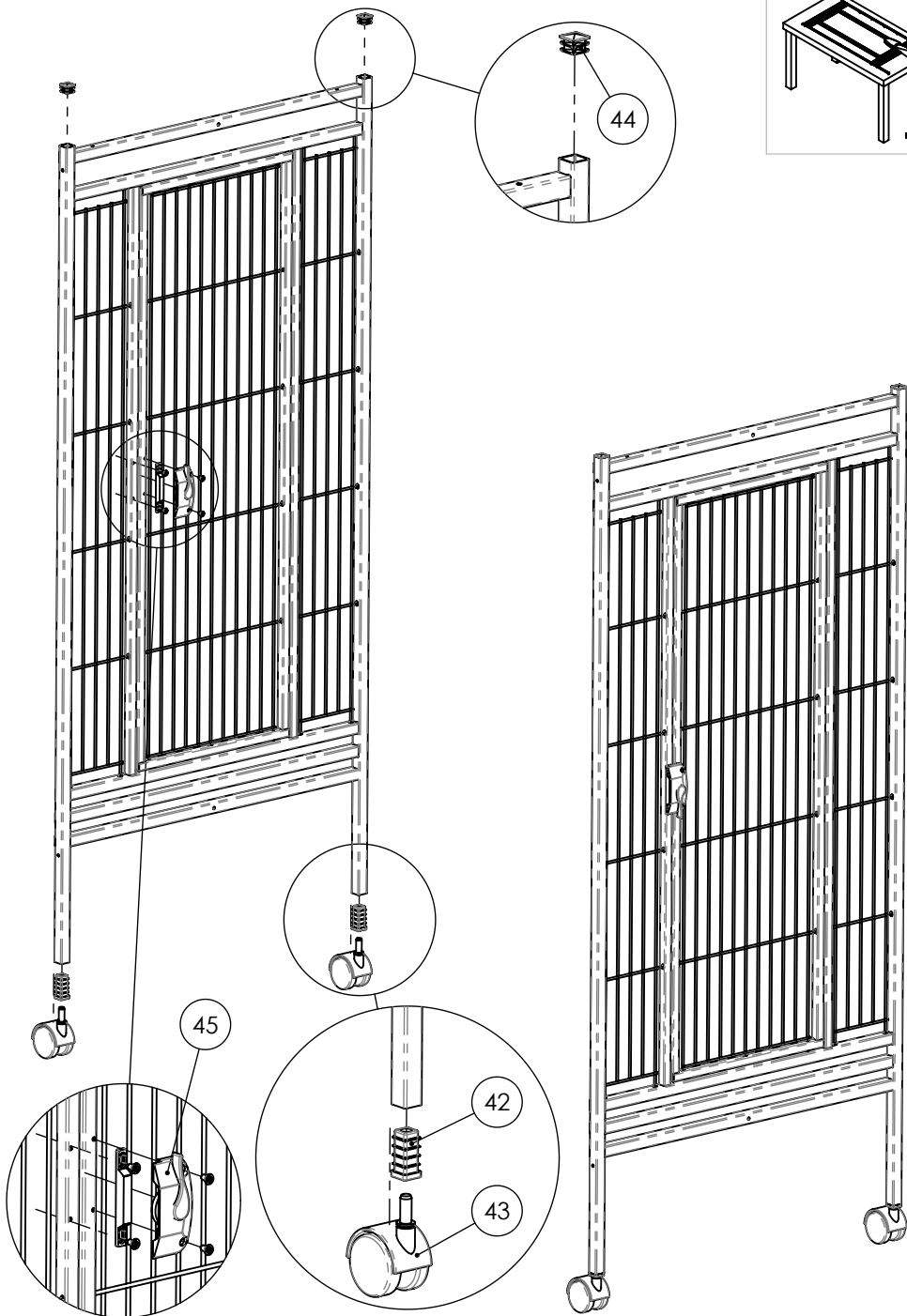
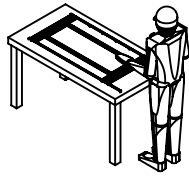

OP6

HOW TO WORK

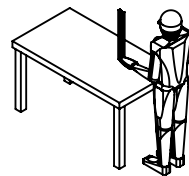

LOWER TUBES  
INFERIOR TUBES

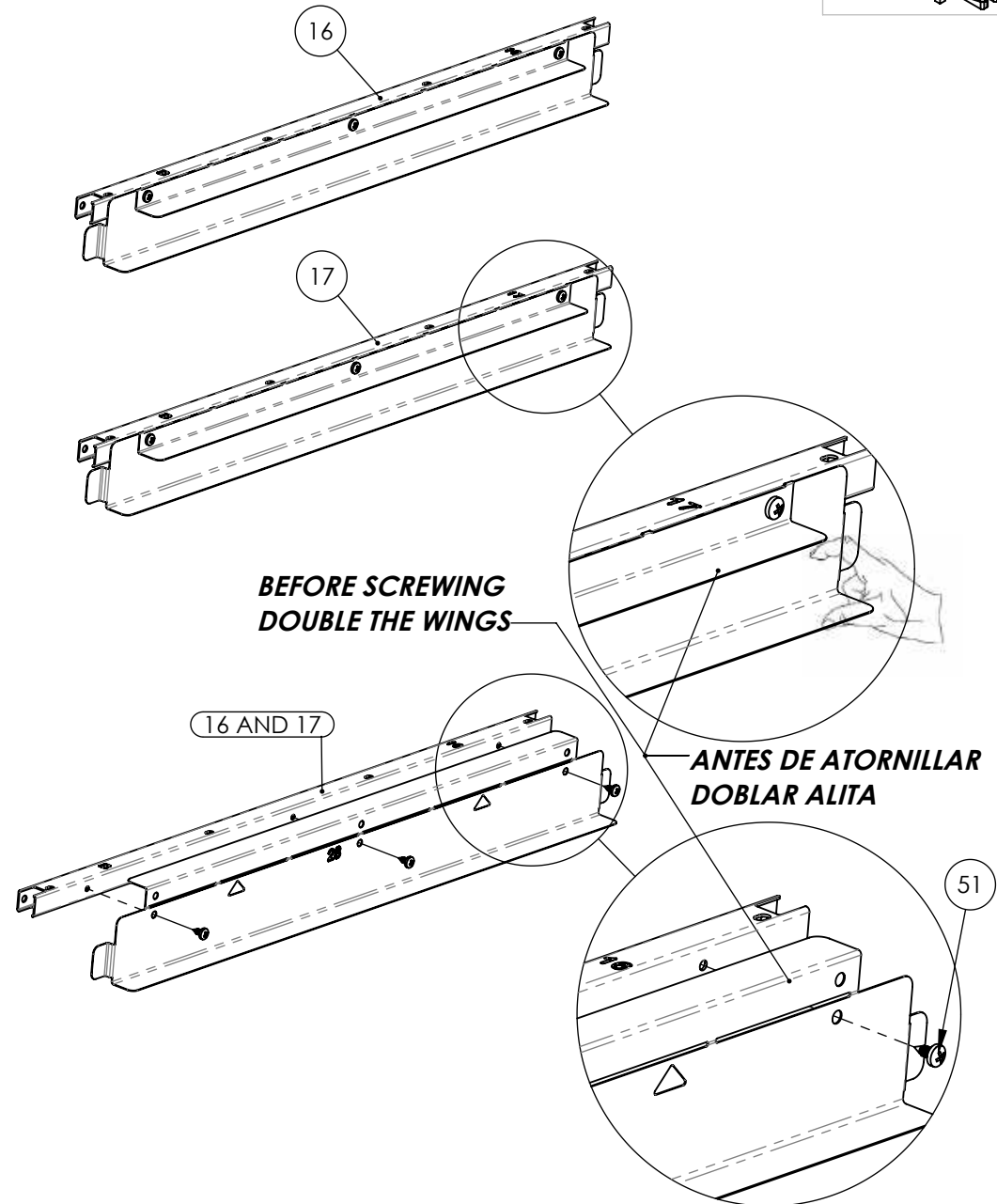

OP7

**UPPER TUBES  
SUPERIOR TUBES**

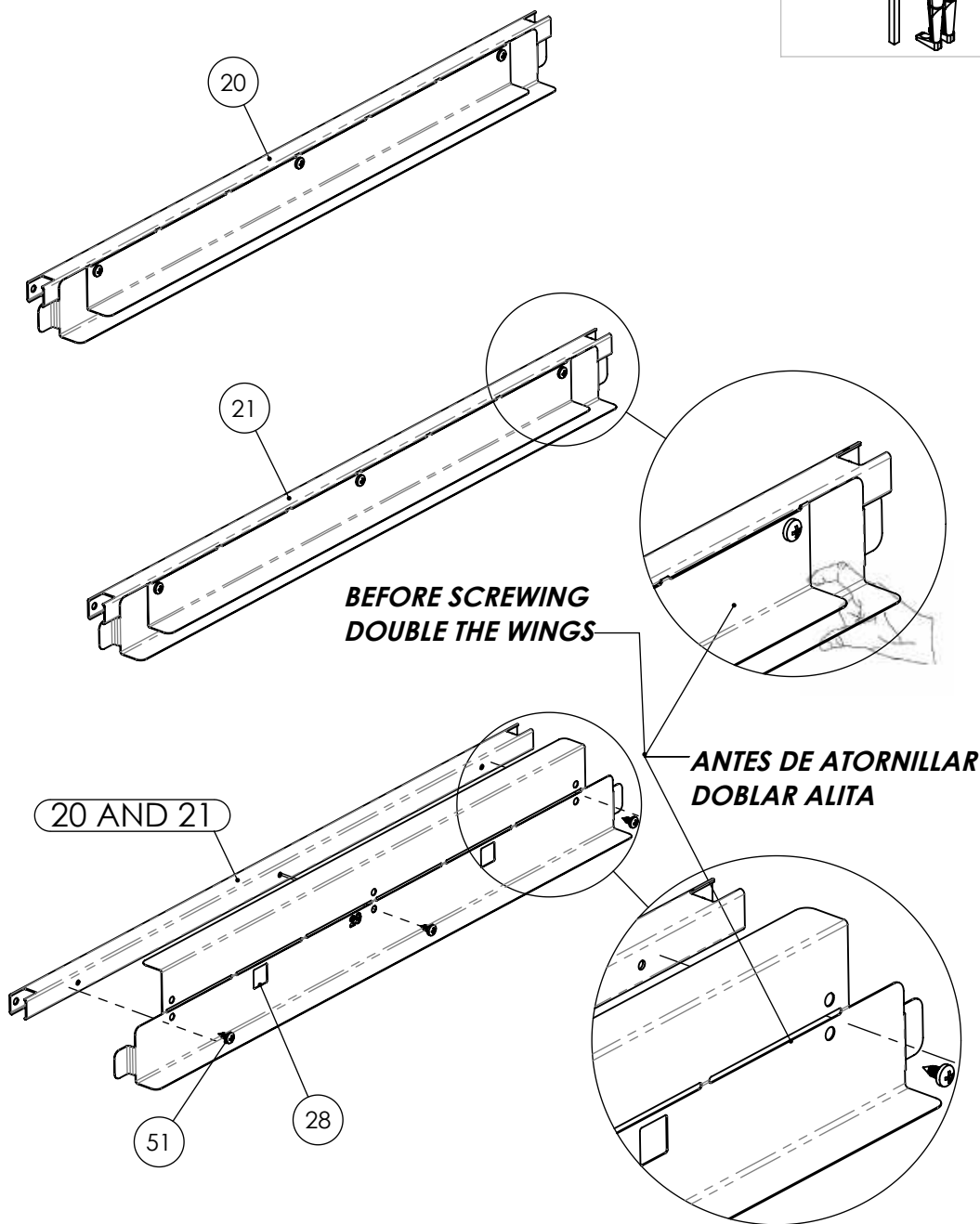

HOW TO WORK

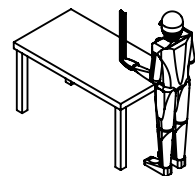

OP8

HOW TO WORK

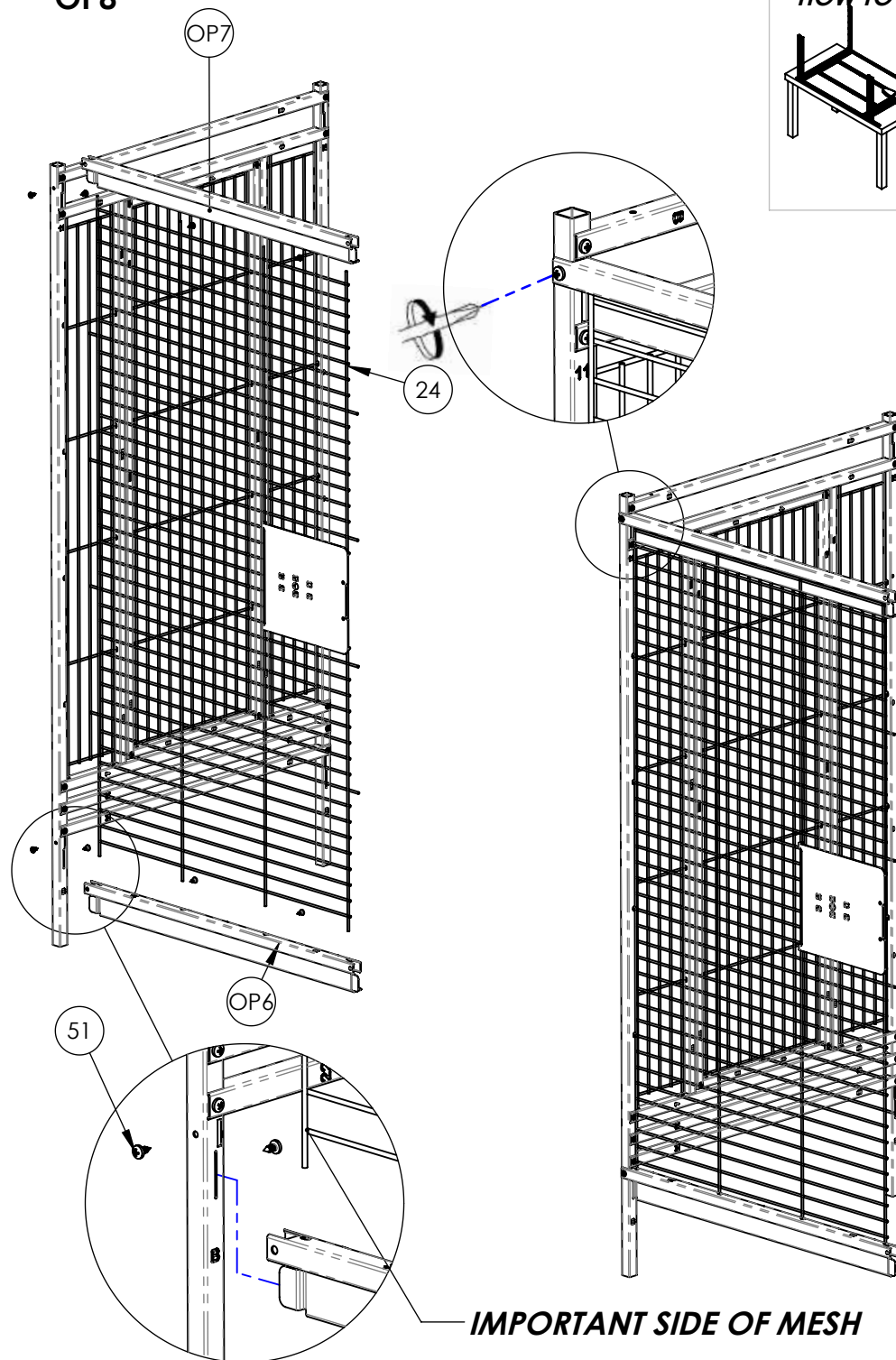
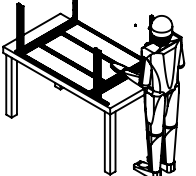

OP9

HOW TO WORK

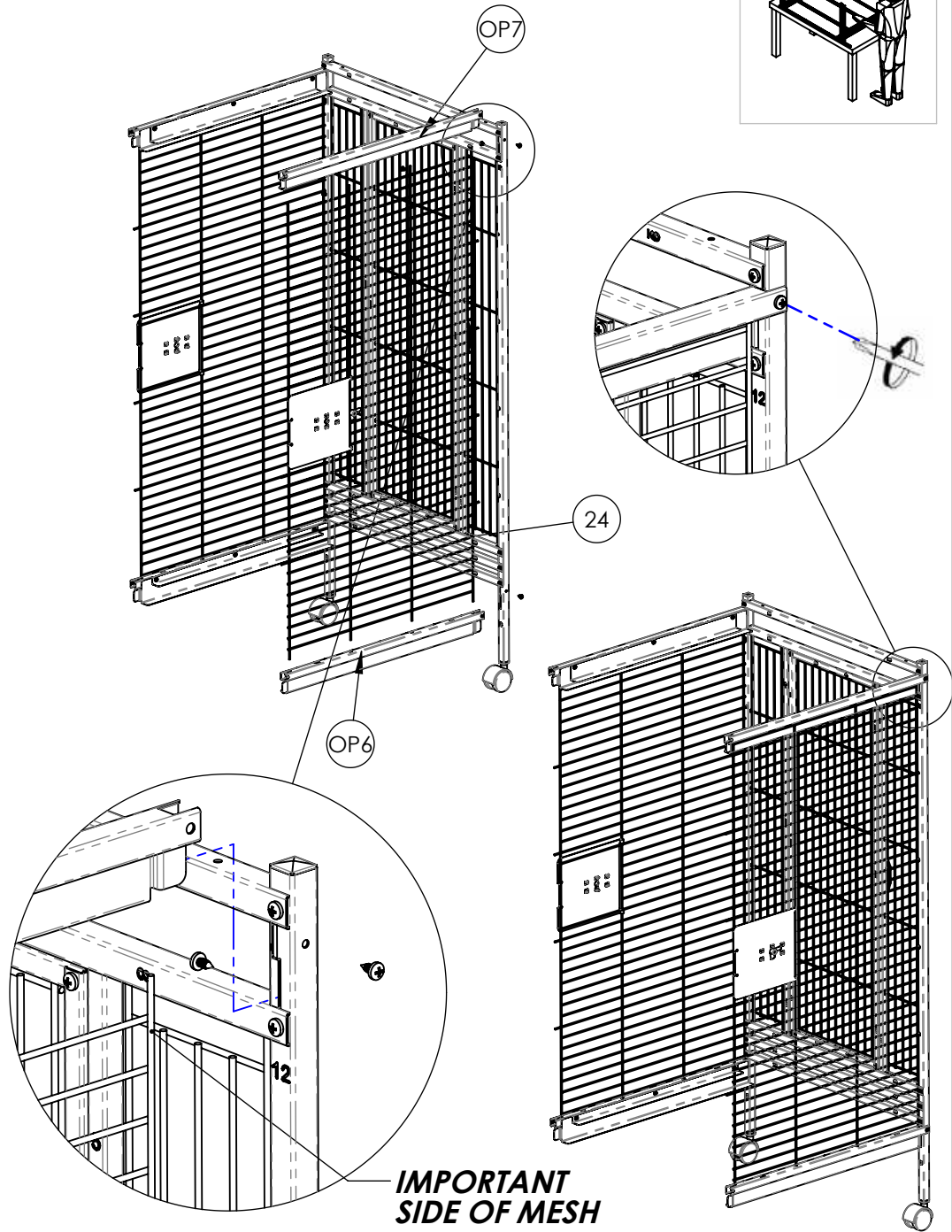
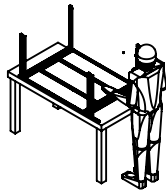

OP10

HOW TO WORK

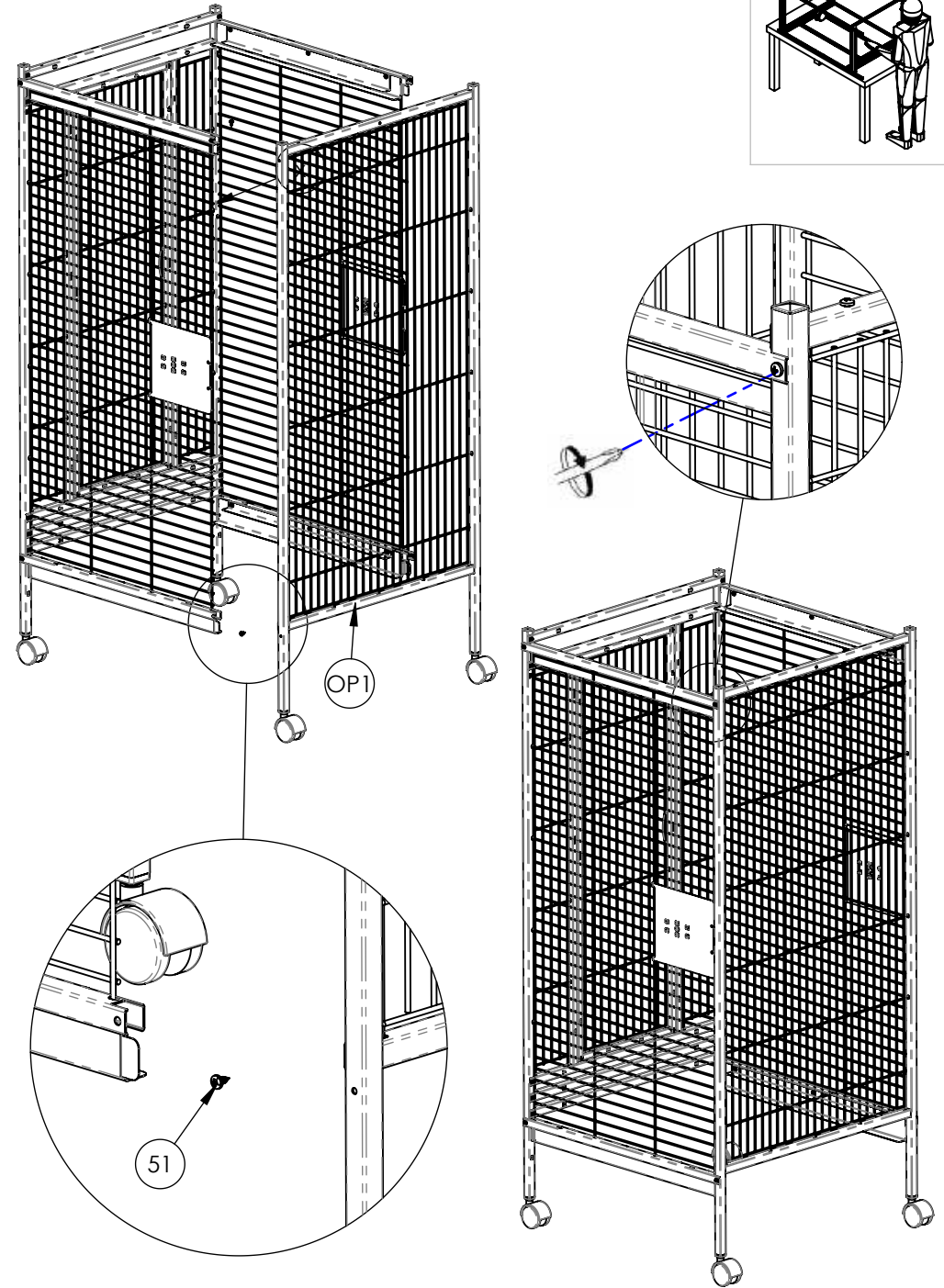
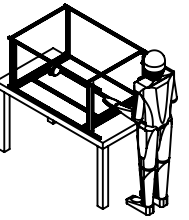



# OP11

## HOW TO WORK

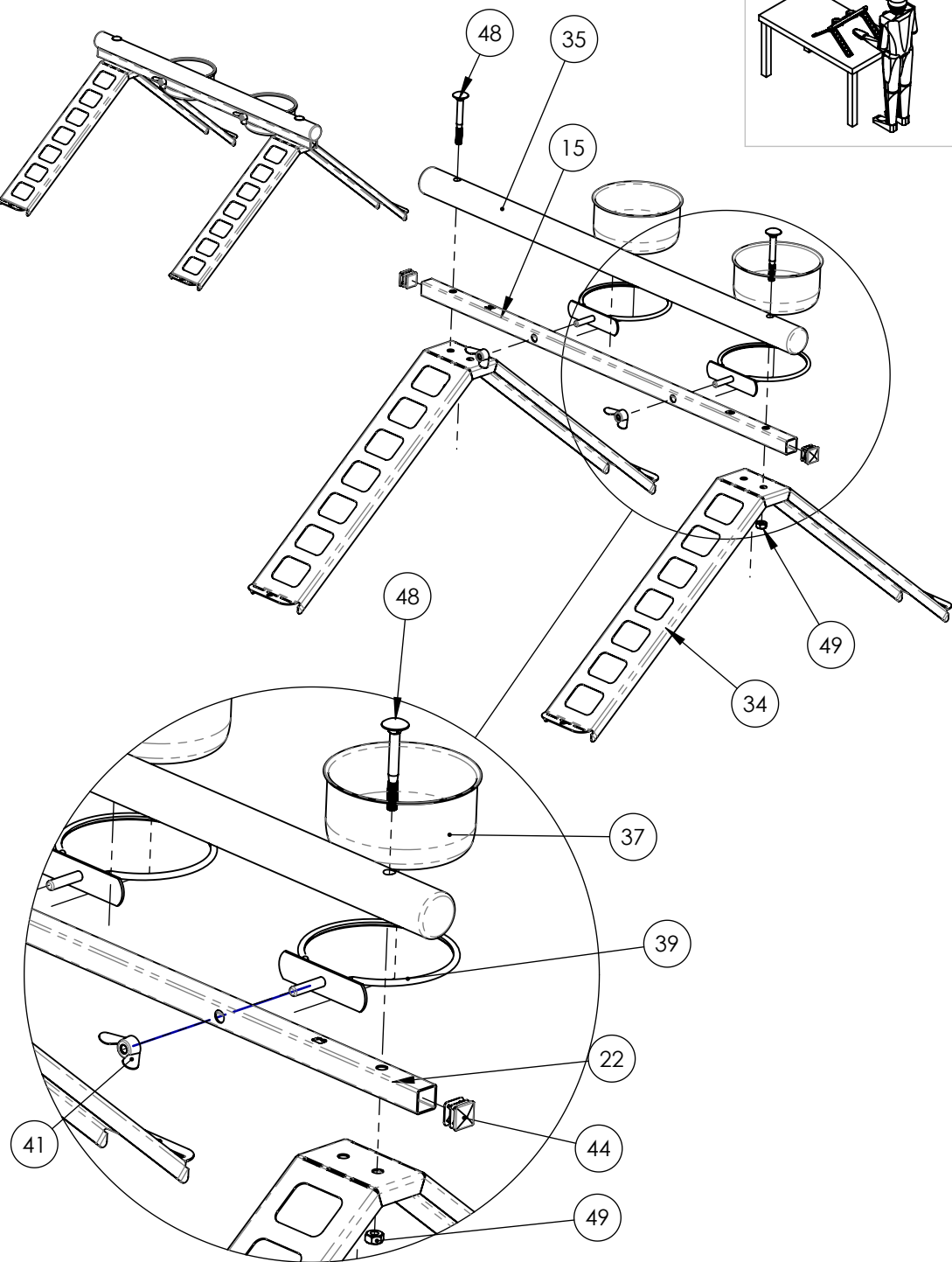
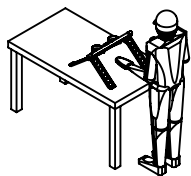

# OP12

## HOW TO WORK

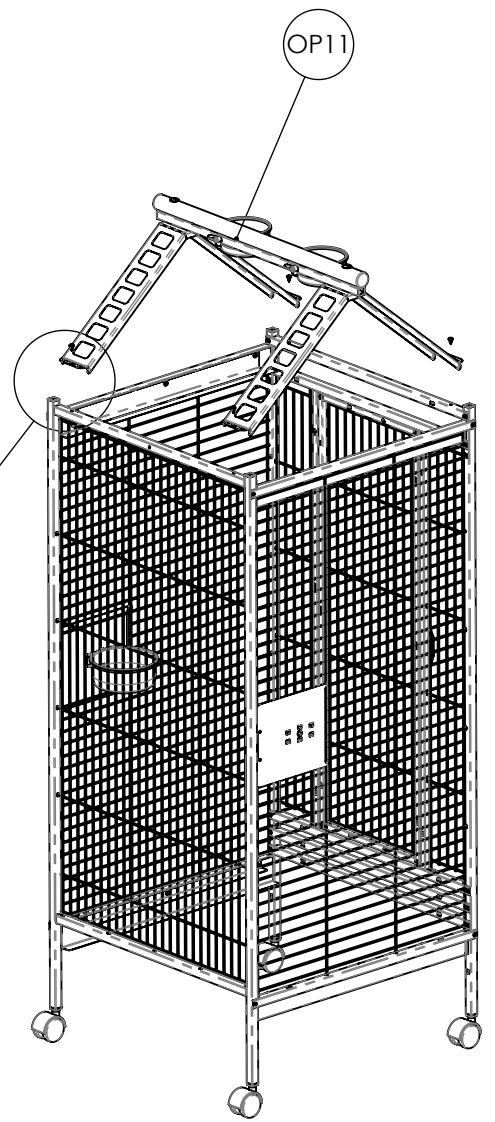
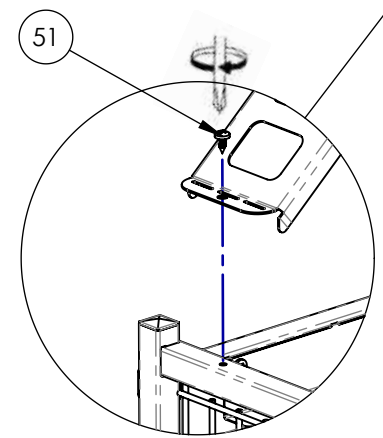
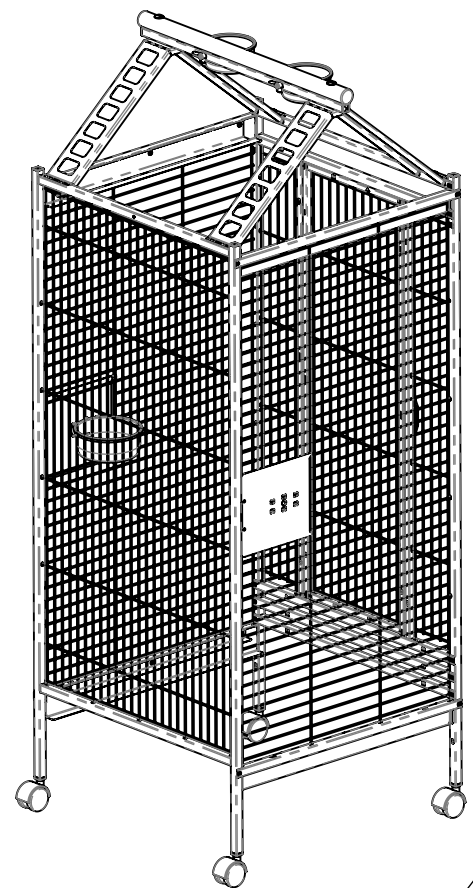
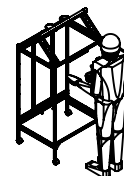

OP13

HOW TO WORK

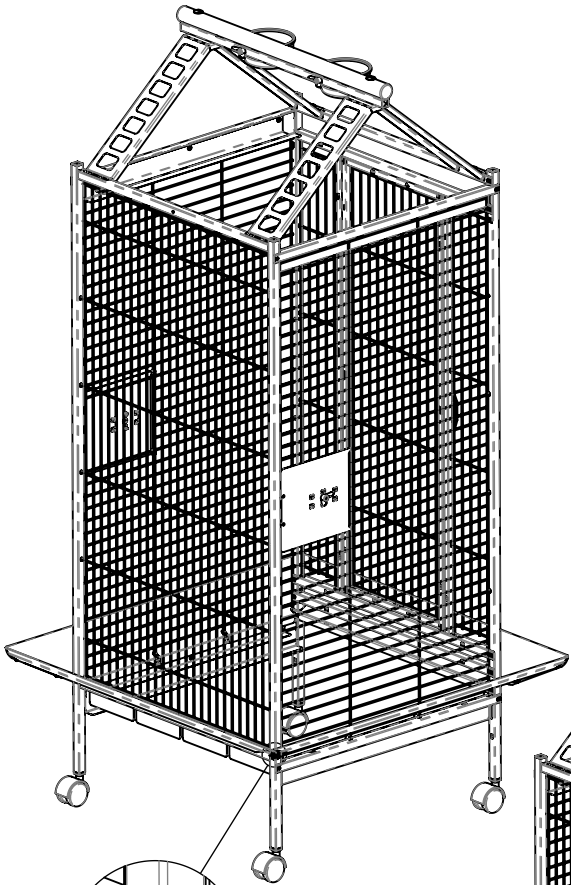
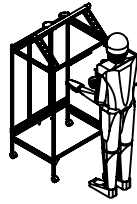

CAUTION!! THE FALDON HAVE TO INTRODUCE BETWEEN THE TWO FILS

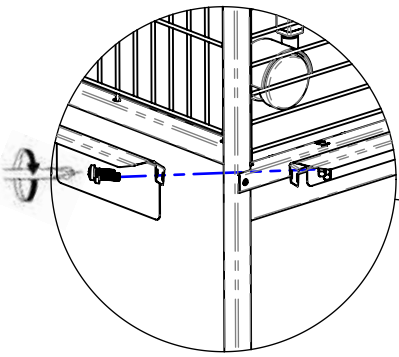
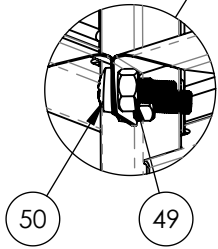
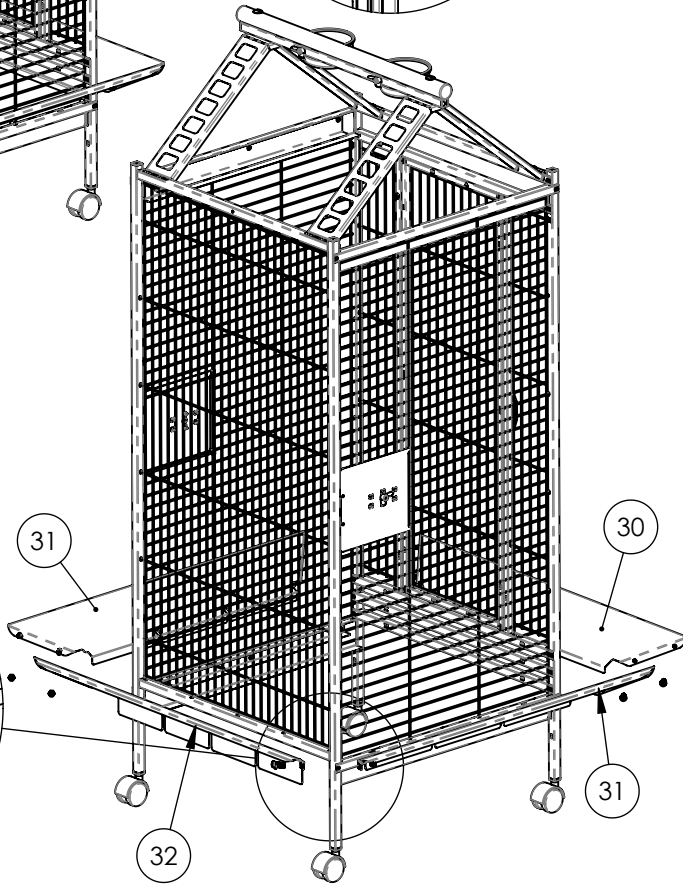
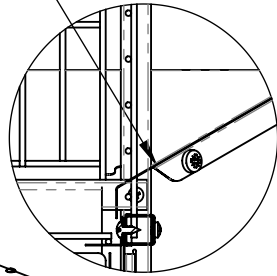

OP14

HOW TO WORK

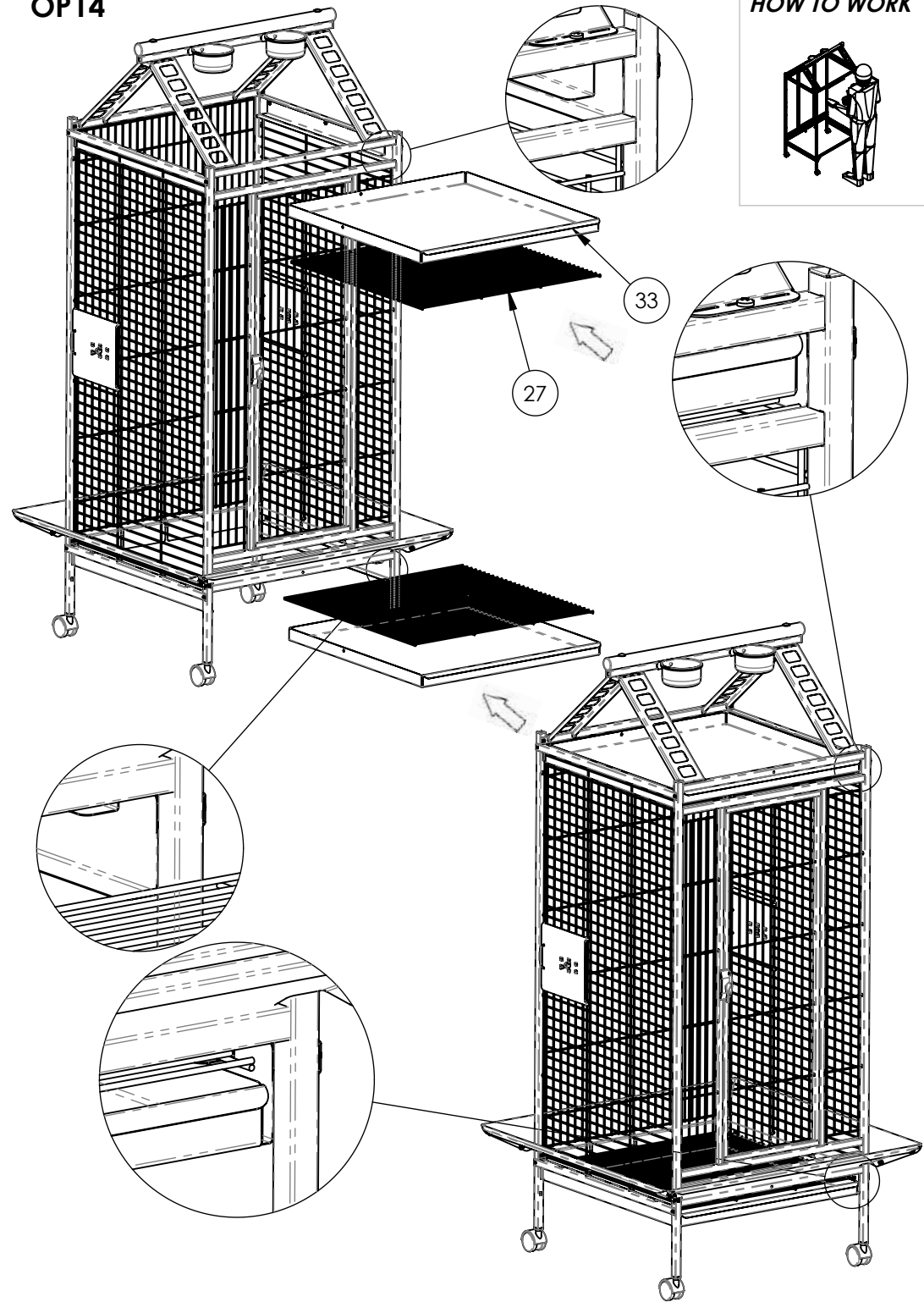
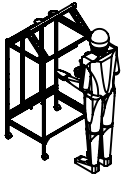

OP15

HOW TO WORK

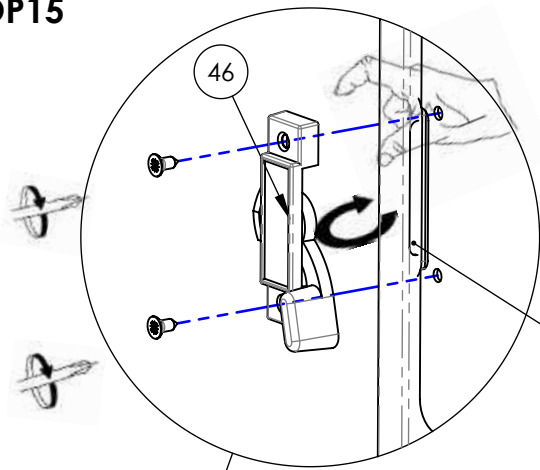
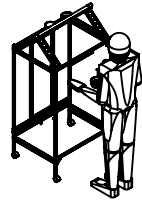

**CRASH THIS UNIT**

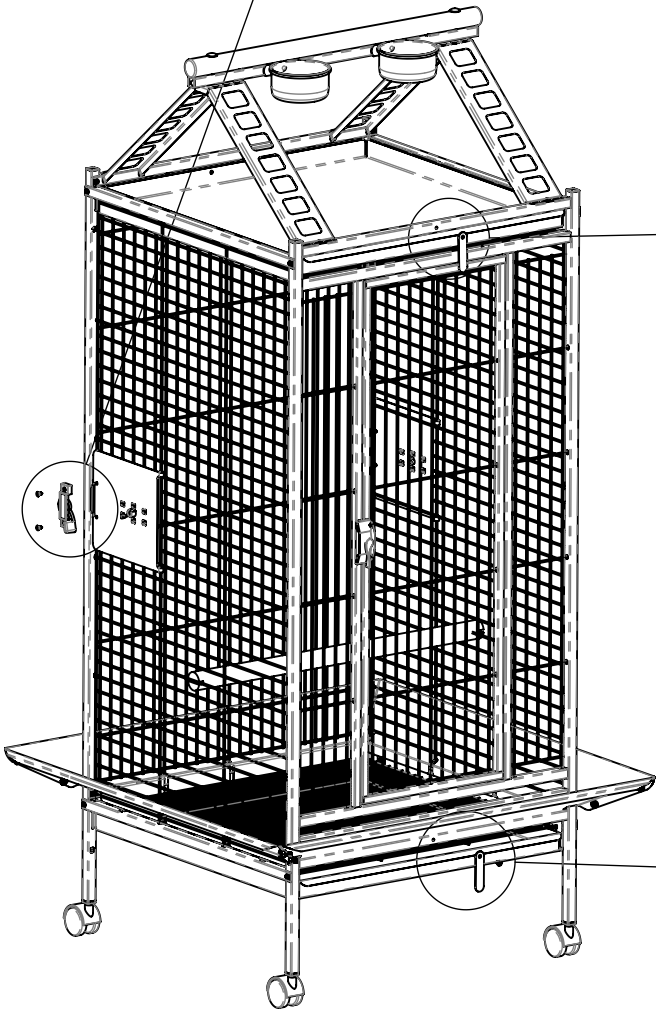
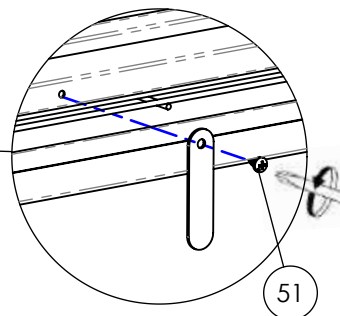
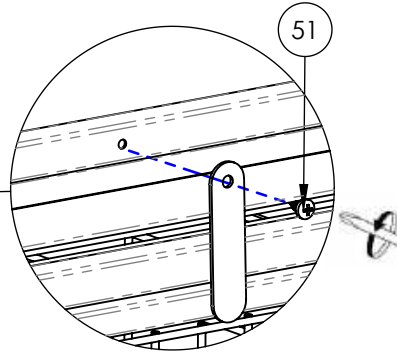

OP16

HOW TO WORK

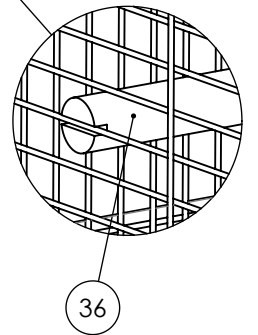
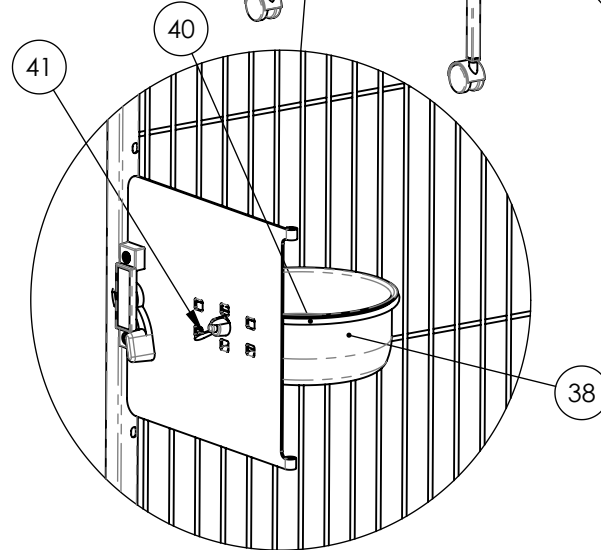
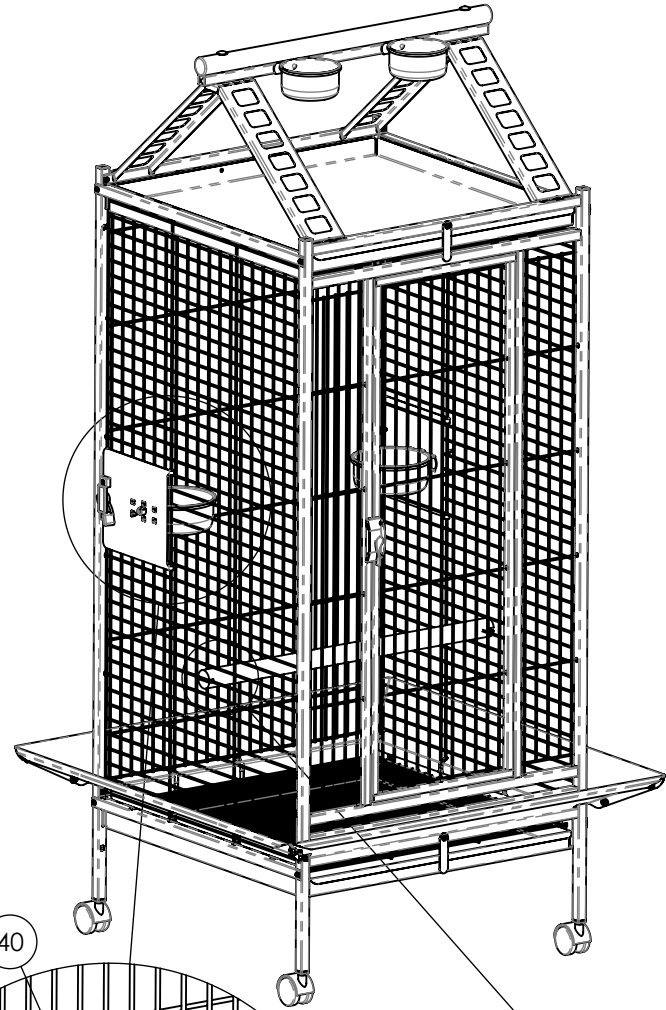
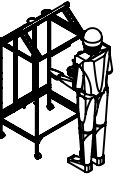

**TURN AND BRAKE**

